



**Card  
Printer  
Solutions**

# P420i Plastic Card Printer

General information

Getting started

Operation

Printing a card

Cleaning

Troubleshooting

Specifications

Appendix A

Appendix B

Appendix C

## Welcome to your new P420i User's Manual

User's Manual No. 980457-001

Rev. A



# P420i Plastic Card Printer

General information

Getting started

Operation

Printing a card

Cleaning

Troubleshooting

Specifications

Appendix A

Appendix B

Appendix C

## ***FOREWORD***

---

This manual contains installation and operation information for the Zebra P420i by Zebra Technologies Corporation.

## ***RETURN MATERIALS AUTHORIZATION***

---

Before returning any equipment to Zebra Technologies Corporation for in-warranty or out-of-warranty repair, contact Repair Administration for a Return Materials Authorization (RMA) number. Repack the equipment in the original packing material and mark the RMA number clearly on the outside. Ship the equipment, freight prepaid, to the address listed below:

For USA, and Latin America  
Zebra Technologies Corporation  
Card Imaging Division  
1001 Flynn Road  
Camarillo, CA. 93012-8706. USA  
Phone: +1 (805) 579 1800  
Fax: +1 (805) 579 1808  
Toll Free in US: (800) 452-4056

For Europe, Asia and Pacific:  
Zebra Technologies France  
Card Imaging Division  
Zone Industrielle, Rue d'Amsterdam  
44370 Varades, France  
phone: +33 (0) 240 097 070  
Fax: +33 (0) 240 834 745

## ***COPYRIGHT NOTICE***

---

This document contains information proprietary to Zebra Technologies Corporation. This document and the information contained within is copyrighted by Zebra Technologies Corporation and may not be duplicated in full or in part by any person without written approval from Zebra. While every effort has been made to keep the information contained within current and accurate as of the date of publication, no guarantee is given or implied that the document is error-free or that it is accurate with regard to any specification. Zebra reserves the right to make changes, for the purpose of product improvement, at any time.

## ***TRADEMARKS***

---

P420i is a service mark and Zebra is a registered trademark of Zebra Technologies Corporation. Windows and MS-DOS are registered trademarks of Microsoft Corp. All other marks are trademarks or registered trademarks of their respective holders.



# P420i Plastic Card Printer

## PRODUCT WARRANTY STATEMENT

General information

Getting started

Operation

Printing a card

Cleaning

Troubleshooting

Specifications

Appendix A

Appendix B

Appendix C

### Printers

All Zebra Card Printers are warranted against defects in material or workmanship for twelve (12) months from the purchase date.

Proof of purchase or shipment date is required to validate the warranty period. The warranty becomes void if the equipment is modified, improperly installed or used, damaged by accident or neglect, or if any parts are improperly installed or replaced by the user.

*Note: Products returned must be packaged in the original or comparable packing and shipping container. In the event equipment is not so packaged, or if shipping damage is evident, it will not be accepted for service under warranty. Surface transportation charges for return to customers in the continental United States is paid by Zebra. Otherwise, Zebra pays CPT (carriage paid to) nearest airport, customer pays customers, duties, taxes, and freight from airport to destination. If Zebra determines that the product returned for warranty service or replacement is not defective as herein defined, the customer will pay all handling and transportation costs.*

### Printheads

Since printhead wear is part of normal operation, the original printhead is covered by a twelve (12) month warranty. Warranty period begins on purchase date.

To qualify for this warranty, the printhead must be returned to the factory or to an authorized service center. Customers are not required to purchase Zebra supplies (media and/or ribbons) for warranty qualification. However, if it is determined that the use of other manufacturer supplies has caused any defect in the printhead for which a warranty claim is made, the user is responsible for Zebra's labor and material charges required to repair the defect. The warranty becomes void if the printhead is physically worn or damaged; also if it is determined that failure to follow the preventive maintenance schedule listed in the User's Guide has caused defect in the thermal printhead for which a warranty claim is made.

### Spare Parts

All parts, maintenance kits, options kits, and accessories are warranted to be free of defects in material and workmanship for 90 days (except where otherwise denoted) from date of purchase. This warranty become void if the item is modified, improperly installed or used, or damaged by accident or neglect.



# P420i Plastic Card Printer

General information

Getting started

Operation

Printing a card

Cleaning

Troubleshooting

Specifications

Appendix A

Appendix B

Appendix C

## ***DECLARATIONS OF CONFORMITY***



European Council Directive		Compliance to Standards	
89/336/EEC modified by 92/31/EEC and 93/68/EEC	EMC Directive	EN 55022-B	RF Emissions control
	EMC Directive	EN 500082-1,1992	Immunity to Electromagnetic Disturbances
73/23/EEC modified by 93/68/EEC	Low voltage Directive	EN 60950	Product safety



**Model:** P420i conforms to the following specification:  
**FCC Part 15, Subpart A, Section 15.107(a) and Section 15.109(a) Class B digital device**

### **Supplemental Information:**

This device complies with Part 15 of the FCC Rules. Operation is subject to the following two conditions: (1) This device may not cause harmful interference, and (2) this device must accept any interference received, including interference that may cause undesired operation.

### **Note:**

This equipment has been tested and found to comply with the limits for a class B digital device, pursuant to Part 15 of the FCC Rules. These limits are designed to provide reasonable protection against harmful interference when the equipment is operated in a commercial environment. This equipment generates, uses, and can radiate radio frequency energy and, if not installed and used in accordance with the instruction manual, may cause harmful interference to radio communications. Operation of this equipment in a residential area is likely to cause harmful interference in which case the user will be required to correct the interference at his own expense.

## ***INDUSTRY CANADA NOTICE***

This device complies with Industry Canada ICS-003 class A requirements.  
Cet équipement est conforme à l'ICS-003 class A de la Norme Industrielle Canadienne.



# P420i Plastic Card Printer

## INTRODUCTION

*Thank you for choosing the Zebra P420i Plastic Card Printer.*

These printers produce cards ideal for personalized identification, access control, visitor, membership, promotion and luggage card, badges and tags.

This manual guides you to an efficient start up and operation of your new Card Printer.

## P420i PRINTER MODELS

The Zebra Product Number tells a story:

Here is a quick review of the Zebra Card Printer Series numbering and lettering system to help you.

The P420i Plastic Card Printer employs Dye Sublimation and Resin Thermal Transfer Technologies. Model numbers include identifiers that specify options are shown using the following lettering conventions:

P 4 2 0 i - X X X X X - X X X

**Smart card :** \_\_\_\_\_

- O = No
- E = Yes

**Magnetic encoder:** \_\_\_\_\_

- O = No
- M = Yes

**Magnetic encoder option:** \_\_\_\_\_

- O = No
- 1 = Stripe Down HICO
- 2 = Stripe Down LOCO
- 3 = Stripe Up HICO
- 4 = Stripe Up LOCO

**Memory :** \_\_\_\_\_

- O = Standard

**Interface :** \_\_\_\_\_

- P = Parallel (Centronics 36 broches)
- U = USB + Centronic Parallel

**Software :**

- O = Demo software

**Languages :**

- D = Drivers & Documentation CD's

**Power cord:**

- O = None
- I = 120 VAC - 220 VAC
- U = UK

General information

Getting started

Operation

Printing a card

Cleaning

Troubleshooting

Specifications

Appendix A

Appendix B

Appendix C



# P420i Plastic Card Printer

General information

Getting started

Operation

Printing a card

Cleaning

Troubleshooting

Specifications

Appendix A

Appendix B

Appendix C

## *ICONS*

Throughout this manual, different icons highlight important information, as follows:



Important general information.



Mechanical hazard, such as one associated with moving parts, capable of resulting in equipment damage or personal injury.



Electrical hazard, such as an exposed voltage point, capable of causing electrical shock and personal injury.



An area where electrostatic discharge (ESD) can cause component damage. Use a grounding wrist band.



Elevated temperature hazard, capable of producing a burn.



Keep Card Printer clean by minimizing cover open time.



# P420i Plastic Card Printer

## Table of contents

General information

Getting started

Operation

Printing a card

Cleaning

Troubleshooting

Specifications

Appendix A

Appendix B

Appendix C

<b>1</b>	<b>GETTING STARTED</b> .....	<b>1</b>
	1•1 Unpacking your card printer .....	1
	1•2 Indicators and control .....	3
	1•3 Printer Installation .....	4
<b>2</b>	<b>OPERATION</b> .....	<b>5</b>
	2•1 Printer Features .....	5
	2•2 Loading ribbons .....	6
	2•3 Loading cards .....	8
	A- Card Feeder .....	8
	B- Card Cleaning Cartridge .....	9
	C- Card Thickness Control Lever .....	10
	D- Card Output Hopper .....	10
	2•4 Reject Card Box .....	11
	2•5 Feeding one card at a time .....	13
	2•6 Printing a test card .....	14
	2•7 Printer menu information .....	15
<b>3</b>	<b>PRINTING A SAMPLE CARD</b> .....	<b>18</b>
	A- Install Driver on windows 95/98 .....	19
	B- Install Driver on windows NT4.0 .....	20
	C- Set Printer Driver Options .....	20
	D- Printing a Sample Card .....	21
<b>4</b>	<b>CLEANING</b> .....	<b>22</b>
	4•1 Cleaning system .....	23
	4•2 Cleaning the print head .....	24
	4•3 Card Cleaning Cartridge .....	25
<b>5</b>	<b>TROUBLESHOOTING</b> .....	<b>27</b>
	5•1 Interpreting LCD Display messages .....	27
	5•2 Print Quality Issues .....	30
<b>6</b>	<b>TECHNICAL SPECIFICATIONS</b> .....	<b>33</b>



# P420i Plastic Card Printer

General information

Getting started

Operation

Printing a card

Cleaning

Troubleshooting

Specifications

Appendix A

Appendix B

Appendix C

<b>APPENDIX A - MAGNETIC CARD STRIPE ENCODER</b> .....	<b>37</b>
<i>Introduction</i> .....	37
A- Media Loading Orientation .....	38
B- Magnetic Encoder Cleaning .....	38
<b>APPENDIX B - SMART CARD CONTACT STATION</b> .....	<b>40</b>
<i>Introduction</i> .....	40
A- Media Loading Orientation .....	41
B- Magnetic Encoder Cleaning .....	41
<b>APPENDIX C - ACCESSORIES AND SUPPLIES</b> .....	<b>42</b>
Ribbons .....	42
Cards .....	43
Accessories .....	44





# P420i Plastic Card Printer

General information

Getting started

Operation

Printing a card

Cleaning

Troubleshooting

Specifications

Appendix A

Appendix B

Appendix C

## GETTING STARTED

---

### 1•1 Unpacking your card printer

Your P420i printer ships in a carton and protective anti-static bag. Keep all packing material in case you need to move or re-ship the printer.

While unpacking, inspect the carton to ensure that no damage occurred during shipping.

Please ensure that you have a clean and nearly dust free environment for proper operation and storage of the printer.



# P420i Plastic Card Printer

General information

Getting started

Operation

Printing a card

Cleaning

Troubleshooting

Specifications

Appendix A

Appendix B

Appendix C

In addition to user documentation, make sure the following items are included with your P420i printer:

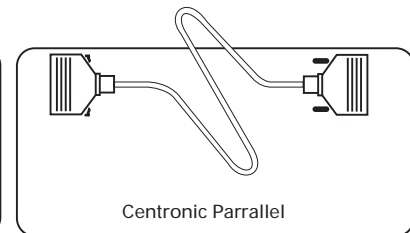
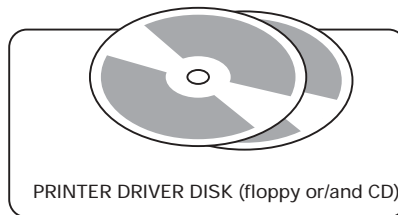
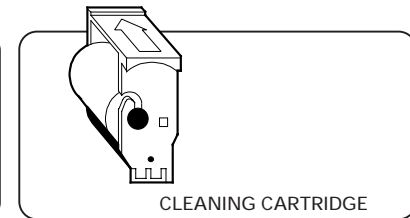
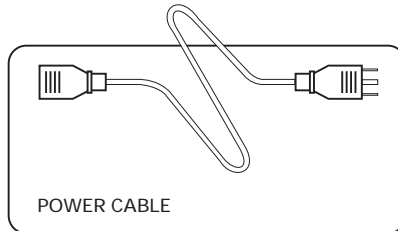
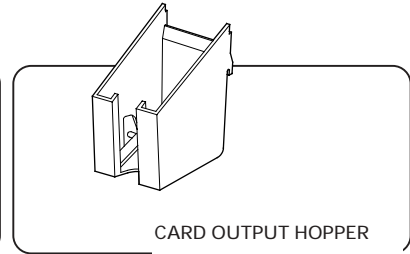
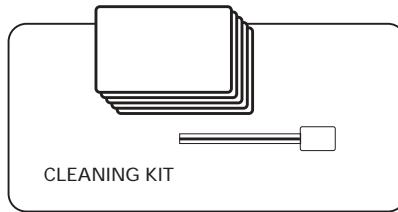

If any items are missing, please contact your dealer.

To reorder, please refer to Appendix C of this manual.



# P420i Plastic Card Printer

## 1•2 Indicators and Control

Your P720 printer has an LCD Display, two LED's and two Panel Buttons.

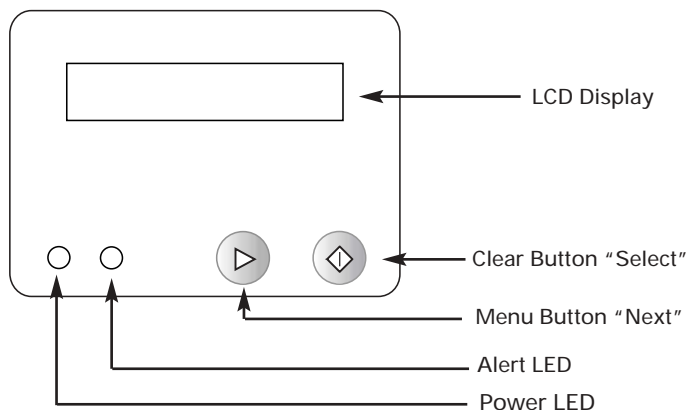

### LCD Display:

The 16 character LCD Display is used for:

- Showing the printer's current status
- Providing operator and service messages (chapter 5)

### LEDs:

The two LEDs are used for:

- Green: Power LED
- Amber: Alert LED (with Beeper)

This Alert LED is on when an error condition exists. The Beeper will sound three alert "Beeps" and the LCD Display will show the associated error message.

### Panel Buttons:

The Menu Button (left) is a push button used for:

- Bringing printer into Menu Mode when pressed with the printer showing READY on the LCD Display.
- Using in Menu Mode to scroll through Menu Options.

The Clear Button (right) is a push button used for:

- Clearing an error status (when LCD Display shows an error and Alert LED is on).
- Invoking automatic retry of the operation which gave the error.
- Selecting a Menu Option when in Menu Mode.

Note: The buttons beep when pressed.

General information

Getting started

Operation

Printing a card

Cleaning

Troubleshooting

Specifications

Appendix A

Appendix B

Appendix C



# P420i Plastic Card Printer

## 1.3 Printer Installation

The following will guide you through the installation of your P420i printer.

General information

Getting started

Operation

Printing a card

Cleaning

Troubleshooting

Specifications

Appendix A

Appendix B

Appendix C



**CAUTION:** Limit AC power supplied to the P420i Printer to 110 - 230 V AC, 60 - 50 Hz for an associated 680 mA - 310 mA. Limit excess current draw to 16 amps or less, using an associated circuit breaker or other such device. Never operate the printer in a location where operator, computer, or printer can get wet. Personal injury could result. The printer must be connected to an earthed electrical power supply and properly protected against electrical surges and grounding faults.

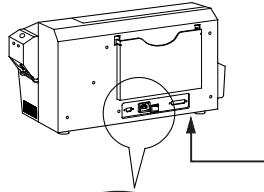

1. Place the printer in a location that allows easy access to all sides. The printer should never be operated while resting on its side or upside down.

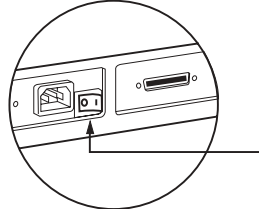

2. Place the printer's power switch in the OFF (0) position.

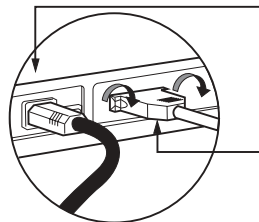

3. Insert the power cable to the printer power socket and attach to grounded electrical socket of the proper voltage and type.

4. Attach interface cable to printer and computer and then secure.

5. Switch power on.



**CAUTION:** Intermittent or unpredictable operation may occur from unsecured connectors. If damaged, the power cable must be replaced by an exact equivalent. Use only Parallel Cable under 3 Meters in length.



# P420i Plastic Card Printer

General information

Getting started

Operation

Printing a card

Cleaning

Troubleshooting

Specifications

Appendix A

Appendix B

Appendix C

## OPERATION

### 2.1 Printer Features

The following shows the features found on your P420i Printer:

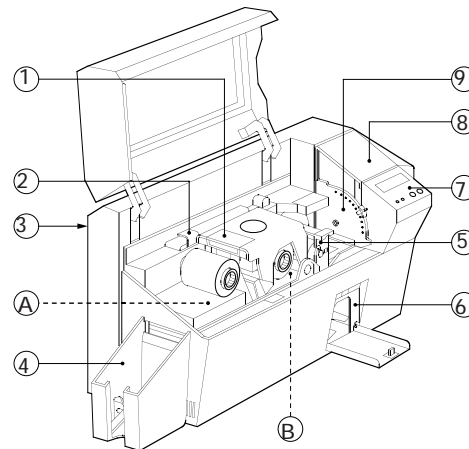

#### STANDARD FEATURES

1. Print Head
2. Print Head Unlock Lever
3. Manual Holder
4. Card Output Hopper
5. Card Cleaning Cartridge
6. Rejected Card Box
7. LCD Display & 2 Panel Buttons
8. Card Feeder + cover
9. Card Thickness Control Lever

#### OPTIONAL FEATURES

- A. Magnetic Encoding Station
- B. Smart Card Contact Station

**PLEASE NOTE:** Any blue items inside the printer can be operated by the user.



# P420i Plastic Card Printer

General information

Getting started

Operation

Printing a card

Cleaning

Troubleshooting

Specifications

Appendix A

Appendix B

Appendix C

## 2·2 Loading Ribbons

The P420i Printer requires approved ribbons (see Appendix C). The Resin Thermal Transfer and Dye Sublimation ribbons and Lamination are specifically designed for your P420i Printer. i Series printers require the use of i Series ribbons for full color printing

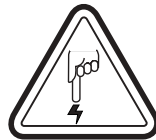

**DO NOT TOUCH** the print head or the electronic components on the print head carriage. Discharges of electrostatic energy that accumulates on the surface of the human body or other surfaces can damage the print head and other electronic components used in the device.

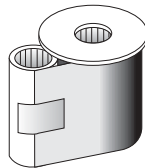

1· Remove ribbon from packaging.

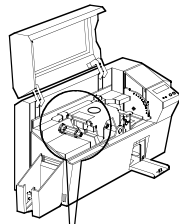

2· With printer power ON and READY status, open cover and press down on the Print Head Unlock Lever to open the print head carriage. The print head carriage will pop open.

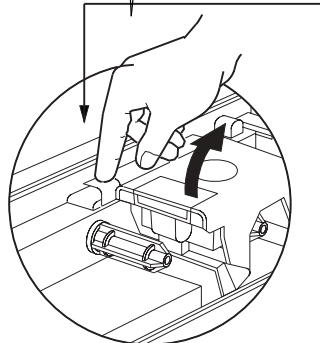

Continued on next page .....



# P420i Plastic Card Printer

General information

Getting started

Operation

Printing a card

Cleaning

Troubleshooting

Specifications

Appendix A

Appendix B

Appendix C

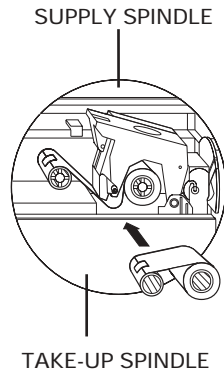

3. Load ribbon onto the supply spindle (under print head carriage) and empty core (with tape attached) onto the take-up spindle. Make sure the ribbon comes off of the top of the supply spindle and feeds to the top of the take-up spindle.

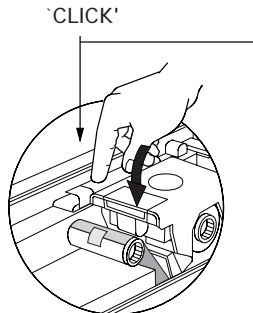

4. Push down on the Print Head Lock Lever until an audible 'click' signals the locked-down position.

5. Close Cover.



Please note that the ribbon automatically synchronizes whenever the print head lock down occurs.

With i Series ribbons, the printer automatically detects the ribbon type inserted.



The card flipper will not operate and an error will be indicated if you try to flip a card when the cover is open.



# P420i Plastic Card Printer

General information

Getting started

Operation

Printing a card

Cleaning

Troubleshooting

Specifications

Appendix A

Appendix B

Appendix C

## 2.3 Loading Cards

To help you load, print, and collect cards, the P420i has the following items:

### A - CARD FEEDER

This items is used for loading cards.

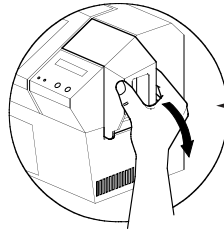

1. Open Card Feeder Cover by putting your fingers on both sides and rotating the cover in a clockwise direction to the open position.

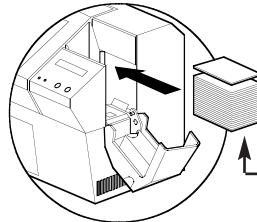

2. Install cards into Feeder\* as shown.

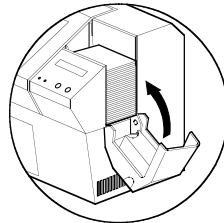

3. Close Card Feeder Cover.



**DO NOT** bend cards or touch print surfaces as this can reduce print quality. The surface of the cards must remain clean and dust free. Always store cards in an enclosed container. Ideally, use cards as soon as possible. If cards stick together, carefully shuffle them.

\* See Chapter 6, Technical Specifications, for card requirements and capacities.





# P420i Plastic Card Printer

General information

Getting started

Operation

Printing a card

Cleaning

Troubleshooting

Specifications

Appendix A

Appendix B

Appendix C

## B - INSTALL CARD CLEANING CARTRIDGE

This item is used to clean the cards entering the printer.

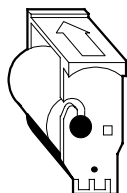

1. Remove Card Cleaning Cartridge from packaging.

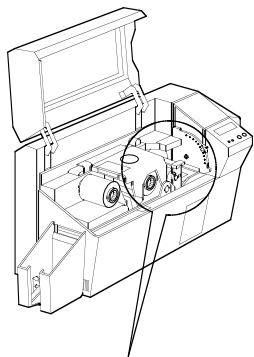

2. Open Printer cover and remove the yellow reminder tape from the location for the Cleaning Cartridge.

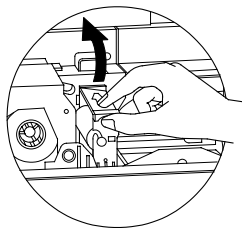

3. Make sure the arrow on top of the assembly is facing toward the rear of the printer. Hook assembly into slot on printer and rotate down. Ensure the assembly locks in place.



# P420i Plastic Card Printer

General information

Getting started

Operation

Printing a card

Cleaning

Troubleshooting

Specifications

Appendix A

Appendix B

Appendix C

## C - CARD THICKNESS CONTROL LEVER

This item is operated by the user to prevent more than one card feeding into the printer at the same time and causing a jam.

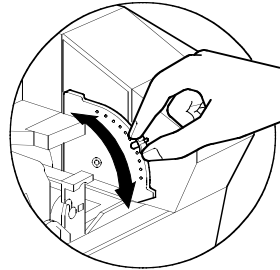

Open Cover, and adjust lever to correct position. Repeat for different card thickness. (Factory setting is for 30mil (0.762mm) card thickness). See diagram below:

### Card Thickness:

A - 60mil (1.524mm) to 50mil (1.27mm)

B - 40mil (1.016mm)

C - 30mil (0.762mm)

D - 20mil (0.508mm)

E\* - Less than 20 mil (0.508mm)

\* Start at lowest position and move lever up to match card thickness.

For other card thickness, start lever at lowest position and move up until cards feed.

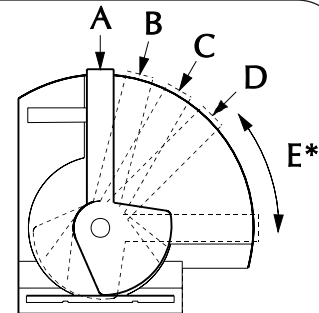

## D - CARD OUTPUT HOPPER

This item is used for collecting printed cards.

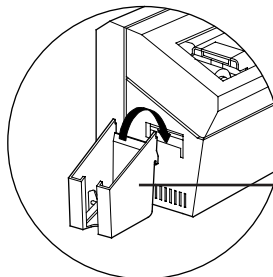

Install Card Output Hopper onto printer by hooking over bottom edge of card exit aperture.



# P420i Plastic Card Printer

## 2•4 Rejected Card Box

The P420i Printer is equipped with a Rejected card Box. When an encoding can not be completed, the card is ejected into the Rejected Card Box. The P420i Printer counts the number of cards which go into the Reject Card Box. After 20 cards the printer stops, the Amber LED Flashes and a LCD Message is displayed indicating the need to empty the reject box.

General information

Getting started

Operation

Printing a card

Cleaning

Troubleshooting

Specifications

Appendix A

Appendix B

Appendix C

**REJECT BOX  
FULL**

### WHEN TO MAINTAIN

When the LCD screen reports message

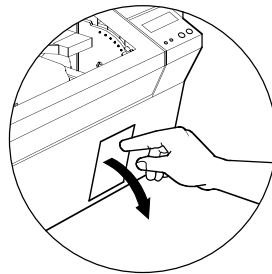

### HOW TO MAINTAIN

1. Press the top of the Rejected Card Box Door as shown. Allow the door to swing down and open.

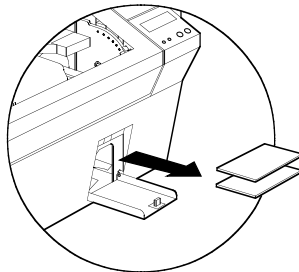

2. Remove all cards from the Rejected Card Box.



# P420i Plastic Card Printer

General information

Getting started

Operation

Printing a card

Cleaning

Troubleshooting

Specifications

Appendix A

Appendix B

Appendix C

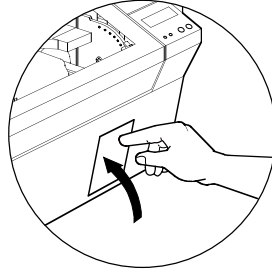

**3.** Swing the Rejected Card Box Door and press the top. An audible “click” signals the locked position.

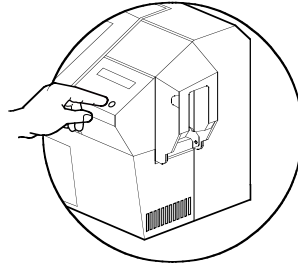

**4.** Press the Clear Button on the front panel to restart the current printer job and to clear the rejected cards counter.



# P420i Plastic Card Printer

## 2•5 Feeding one card at a time

General information

Getting started

Operation

Printing a card

Cleaning

Troubleshooting

Specifications

Appendix A

Appendix B

Appendix C

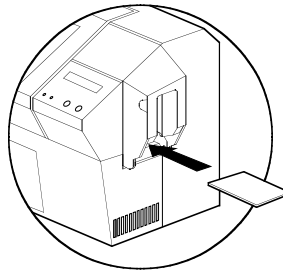

A Manual Feed Slot is available on the side of the Card Feeder cover for feeding single cards. Cleaning Cards are fed manually through this slot.  
The Feeder must be empty for manual card feeding to work properly.

For one-at-a-time printing, feed cards through slot on side of Feeder.

Do not feed more than one card at a time.



# P420i Plastic Card Printer

## 2•6 Printing a Test Card

General information

Getting started

Operation

Printing a card

Cleaning

Troubleshooting

Specifications

Appendix A

Appendix B

Appendix C

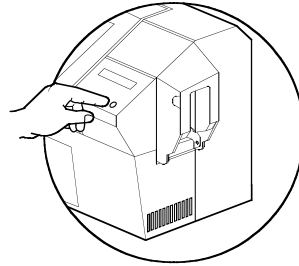

1. When the printer displays *READY*, press the “Next” button (left) on your Control Panel to “*SELF TEST CARD MENU*”, then the “Select” button (right).

2. Press “Next” to the *SELF TEST CARD* Print parameters, and then “Select”.

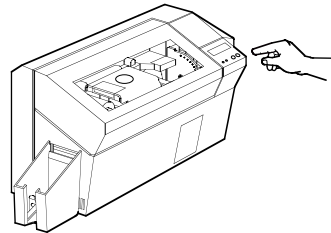

3. A test card will print after a few seconds. LCD display will show printing status. Test Card is printed on both sides of the card.

This is an example of the test card.

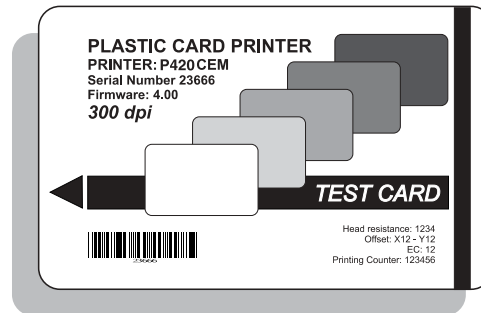

Front Side

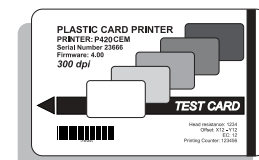

Back Side



# P420i Plastic Card Printer

## 2•7 Printer Menu Information

General information

Getting started

Operation

Printing a card

Cleaning

Troubleshooting

Specifications

Appendix A

Appendix B

Appendix C

The printer is equipped with a LCD Display and two key buttons which gives access to printer menus.

Press the Menu button to enter the Menu Mode

**Menu Button**  
[NEXT]

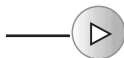

**Clear Button**  
[SELECT]

The top line display shows menu information. The second line of display clarifies the function of the two [NEXT] and [SELECT] key buttons relative to the current menu item.

The printer will return to READY Mode if either of the two key Buttons is not pressed within ten seconds of entering Menu mode.

**See next page:**

### **P420i LCD Menu Tree**

*\*If the printer is equiped with a Magnetic Stripe Encoder*



# P420i Plastic Card Printer

General information

Getting started

Operation

Printing a card

Cleaning

Troubleshooting

Specifications

Appendix A

Appendix B

Appendix C

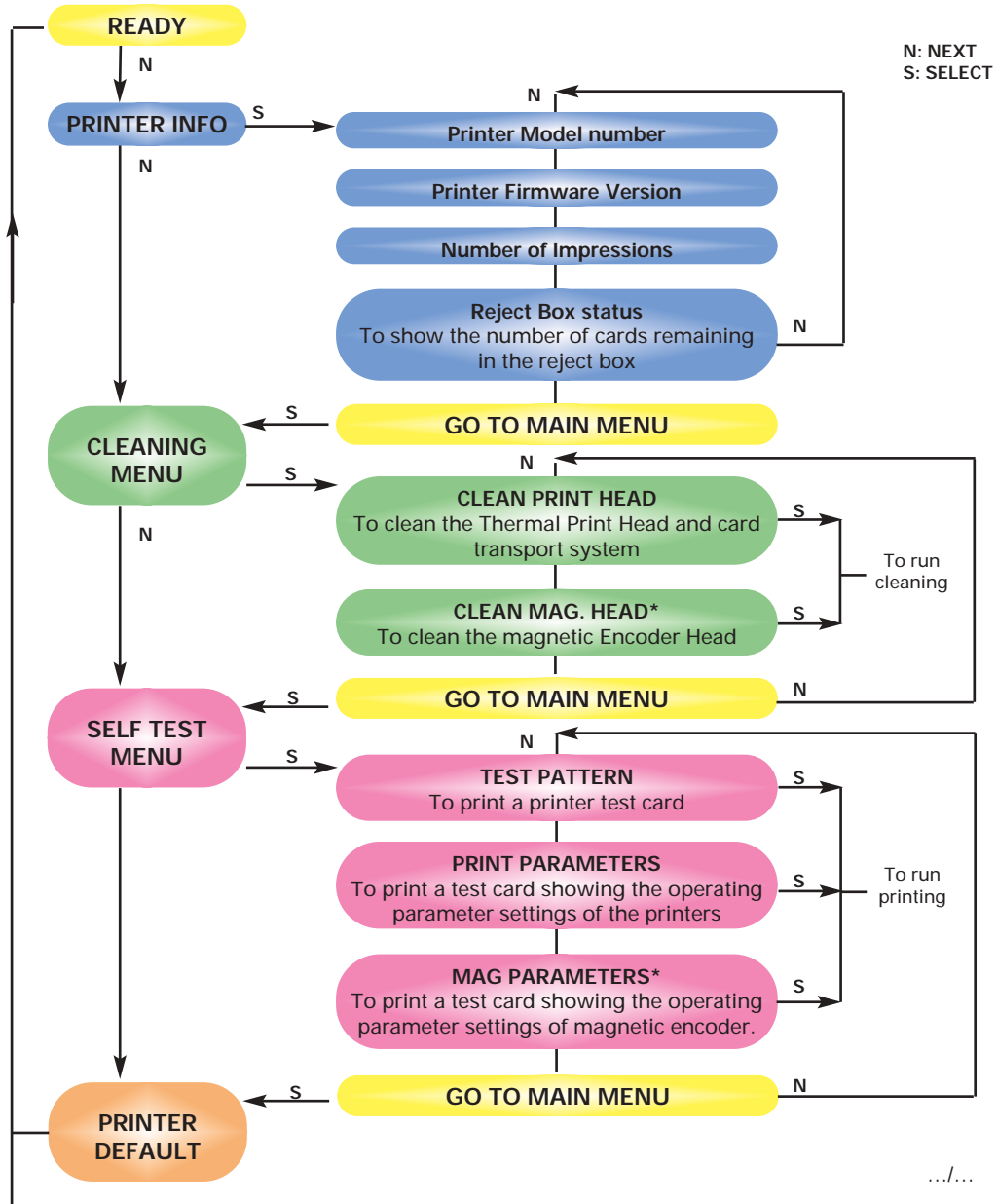





# P420i Plastic Card Printer

General information

Getting started

Operation

Printing a card

Cleaning

Troubleshooting

Specifications

Appendix A

Appendix B

Appendix C

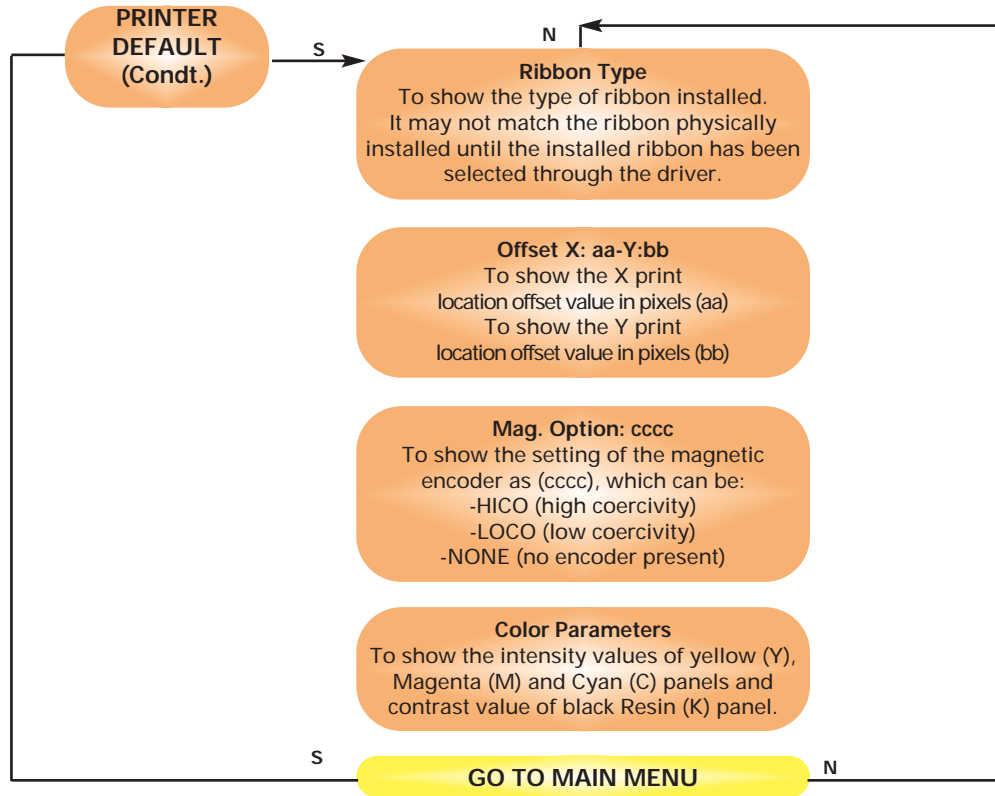



# P420i Plastic Card Printer

General information

Printing

Operation

Printing a card

Cleaning

Troubleshooting

Specifications

Appendix A

Appendix B

Appendix C

## ***PRINTING A SAMPLE CARD***

---

Printing with the P420i Printer requires the Windows Printer Driver, your card design/issuing Windows software or printer command level programming through the printer interface.

The P420i Card Printer can be used with any Windows 95/98/ME/XP/Win 2000, Windows NT 4.0 software application program, using the drivers provided on CD with the printer.

This section contains information on the printing of a dual-sided card in color (using the 6-Panel color ribbon YMCKOK) and the Windows Printer Driver.



**BEFORE** installing updated printer driver versions, always delete the existing printer driver version from your computer.

---



# P420i Plastic Card Printer

General information

nting

Operation

Printing a card

Cleaning

Troubleshooting

Specifications

Appendix A

Appendix B

Appendix C

## 3 • 1. To install the P420i Printer Driver automatically on all Operating systems, use the install wizard.

The wizard will:

- Automatically launch when the driver CD is inserted.
- Check to see which operating system you are using
- Delete previous versions of the driver and clean up any necessary Registry entries.
- You must select "Remove" from the install options to remove any previous driver versions.
- Shut down of PC if necessary.
- Install the new driver files and Registry entries to their correct locations.
- Shutdown of PC is not required, but it is advised.

The install Wizard will walk you through the appropriate steps.



Do not power the printer with USB attached.

The driver will prompt you for USB installation.



# P420i Plastic Card Printer

General information

Getting started

Operation

Printing a card

Cleaning

Troubleshooting

Specifications

Appendix A

Appendix B

Appendix C

## 3•2 Set Printer Driver Options:

To open the P420i Printer screen, right mouse click on your driver icon and select Properties.

Change the options as follows:

1• On the **Device Settings** tab the magnetic encoder feature is automatically enabled. If you need to change settings for a Magnetic Encoder, select **Encoder** settings button.

2• On the **General** tab select card orientation: Landscape or portrait - Select "**Landscape**".  
(in NT, this is located under Document Defaults when you right mouse click from your driver icon. In Windows 2000 and XP, it is located under Print preferences.)

3• In the **Ribbon** section, the ribbon type is automatically detected and enabled for you.

3a• You can click on "ribbon Info" and see how many panels are left.

4• In the same tab, go to Black Panel area and select Text Only. This option allows the text printing using the Black Resin Panel from the Color Ribbon.

5• Close the Zebra P420i Printer screen.  
Now that you have loaded media and set up the printer driver, the P420i Printer is ready to print.



# P420i Plastic Card Printer

General information

Getting started

Operation

Printing a card

Cleaning

Troubleshooting

Specifications

Appendix A

Appendix B

Appendix C

## 3.3. Printing a sample card:

Follow the steps to print your first card

- Go to the Microsoft Word Software.
- If the printer was not selected as the default printer, go to the **File** menu and Select **Printer** and choose **Zebra P420i Card Printer** or **i Series parallel card printer** in the printer names list. Then **Close** the print dialog box.
- Come back to **File** menu and choose **Page Setup**.
- Select **Paper Size** tab and in **Paper Size** choose **Card**. Then select the orientation: "landscape".
- Go to **Margins** tab, put the Top, Bottom, Left and Right margins with 0 values.
- Press **OK** to close **Page Setup** window.
- The card appears on the screen.
- Design a card with 2 sides as follow:



Front Side



Back Side

- Once you are ready to print, go to **File** and point **Print**
- The printer will feed in a card and start printing ( the data download time will vary depending on the complexity of the card design and the processing speed of your computer).
- Once the printing job is achieved the card is ejected from the printer.



# P420i Plastic Card Printer

General information

Getting started

Operation

Printing a card

Cleaning

Troubleshooting

Specifications

Appendix A

Appendix B

Appendix C

## CLEANING



### PROTECT YOUR FACTORY WARRANTY!

The recommended maintenance procedures must be performed to maintain your factory warranty. Other than the recommended cleaning procedures described in this manual, allow only Zebra authorized technicians to service the P420i Printer.

**NEVER** loosen, tighten, adjust, or bend, etc. a part or cable inside the printer.

**NEVER** use a high pressure air compressor to remove particles in the printer.



# P420i Plastic Card Printer

General information

Getting started

Operation

Printing a card

Cleaning

Troubleshooting

Specifications

Appendix A

Appendix B

Appendix C

## 4.1 Cleaning System

Your P420i Printer includes a simple cleaning system using the Pre-Saturated Cleaning Cards provided. The regular use of these cards will clean and maintain important parts of your printer: including the Print Head, and Transport Rollers.

### CLEAN PRINTER

#### WHEN TO CLEAN

*When LCD screen reports message.*

#### HOW TO CLEAN

**1.** Leave power on.

*Open Cover and release Print Head Bracket to remove ribbon.*

*Close Print Head bracket.*

*Close Cover. Remove cards from Card Feeder.*

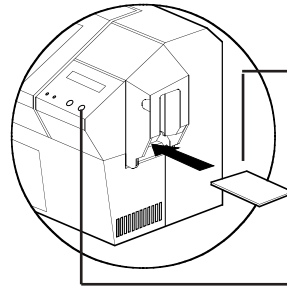

**2.** Insert one Pre-Saturated Cleaning Card (provided) through slot on the side of the Card Cartridge.

**3.** Press the right Panel Button for a few seconds. The card will feed into printer and carry out the cleaning process. Repeat the process with a new Cleaning Card if necessary.

**Note:** For a printer cleaning prior to the WHEN TO CLEAN signal, press the Left Panel Button until the LCD screen shows "CLEANING MENU". Press the right Panel Button to select and one more time again to run the cleaning process (Repeat first steps 1 & 2 above).



Although the CLEAN PRINTER message is displayed until the cleaning process has been performed, the printer will continue to operate.



# P420i Plastic Card Printer

General information

Getting started

Operation

Printing a card

Cleaning

Troubleshooting

Specifications

Appendix A

Appendix B

Appendix C

## 4.2 Cleaning the Print Head

A cleaning using the Cleaning System with cards usually suffices. However, a separate Print Head cleaning using swabs can remove more stubborn deposits when print anomalies persist. To avoid deposits, only use foam-tipped swabs.

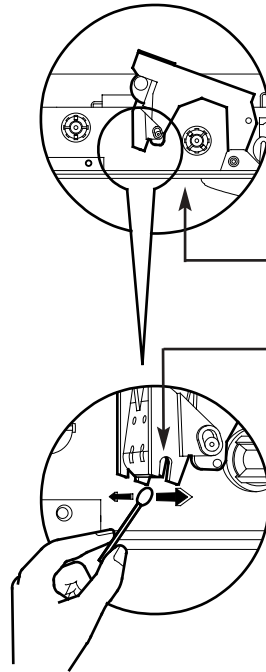

1. Raise Print Head and remove the Ribbon.

2. Clean Print Head by moving alcohol-moistened swab tip side-to-side across Print Head elements. Only use moderate force. (To reorder swabs see Appendix C).



Never use a sharp object to scrape deposits from the print head. Permanent damage will result.





# P420i Plastic Card Printer

General information

Getting started

Operation

Printing a card

Cleaning

Troubleshooting

Specifications

Appendix A

Appendix B

Appendix C

## 4.3 Card Cleaning Cartridge

Your P420i Printer also has a Card Cleaning Cartridge. This item cleans the cards entering the printer. To ensure print quality, the cleaning roller requires periodic replacements.

### **CLEAN PRINTER**

#### WHEN TO MAINTAIN

*When LCD screen reports message.*

*Run a printer cleaning first .*

*(see 4.1 Cleaning System for more instructions.)*

#### HOW TO MAINTAIN

*1. Open Cover and locate Cleaning Cartridge.*

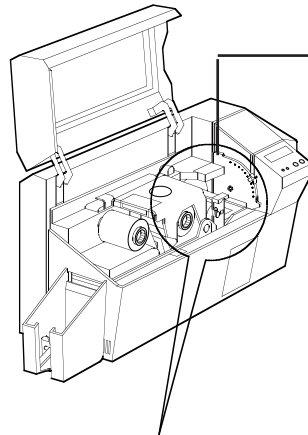

*2. Gently remove Cleaning Cartridge by rotating up and away from printer.*

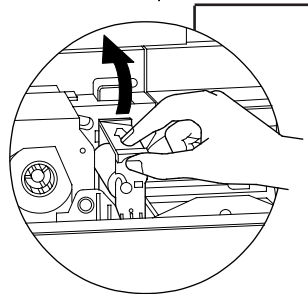

*Continued on next page...*



# P420i Plastic Card Printer

General information

Getting started

Operation

Printing a card

Cleaning

Troubleshooting

Specifications

Appendix A

Appendix B

Appendix C

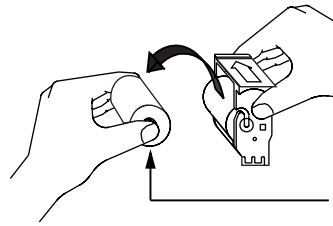

3. Remove Cleaning Roller from Cartridge and discard.

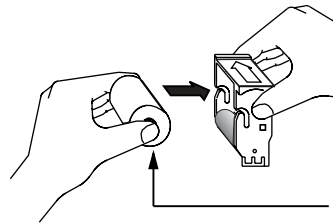

4. Install new Cleaning Roller into Cartridge\*. To avoid contamination, always hold the Cleaning Roller assembly by the ends.

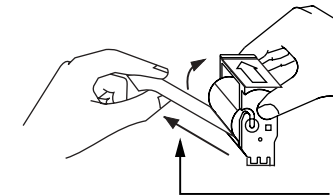

5. Carefully peel off wrapper from new Cleaning Roller while in Cartridge.

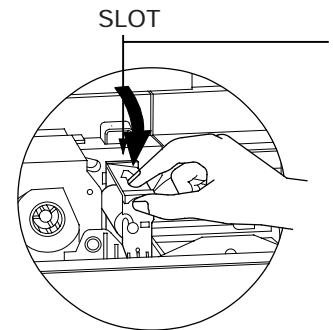

6. Replace Cartridge into printer. Make sure the arrow on top of the assembly is facing toward the rear of the printer. Hook assembly into slot on printer and rotate down. Ensure the assembly locks in place.

DO NOT touch the roller surface that contacts the cards.

7. Close Cover.

\* See Appendix C for replacement Cleaning Rollers.



Although the CLEAN PRINTER message is displayed until maintenance has been performed, the printer will continue to operate.



General information

Getting started

Operation

Printing a card

Cleaning

**Troubleshooting**

Specifications

Appendix A

Appendix B

Appendix C

## TROUBLESHOOTING

This section offers solutions to potential problems you may experience with your P420i printer. The table below lists the screen messages that will be displayed on the printer's LCD, both during normal operation and to alert operator of any error conditions. There is also some additional information dealing with quality issues concerning printing onto cards.

### 5.1 Interpreting LCD Display messages

SCREEN MESSAGE	MEANING	ACTION
INITIALIZING	The printer is performing an internal test before use	Wait for the ready message
READY	Ready for use	
WAIT TEMPERATURE	Print Head cool down mode	Wait for READY message
SELF TEST	Self test card printing	Wait for test card
DOWNLOADING DATA	The card data is being transmitted	Wait for card printing to start
PRINTING YELLOW	The yellow panel is being printed	
PRINTING MAGENTA	The magenta panel is printing	
PRINTING CYAN	The cyan panel is printing	



# P420i Plastic Card Printer

General information

Getting started

Operation

Printing a card

Cleaning

Troubleshooting

Specifications

Appendix A

Appendix B

Appendix C

SCREEN MESSAGE	MEANING	ACTION
ENCODING ERROR	Data cannot be written or read from the card's magnetic stripe	Check that the cards are loaded with the magnetic stripe in the correct orientation. Check whether high or low coercivity cards have been specified. Check that the data conforms to ISO specifications. See Appendix A of this manual for further information.
READING ERROR	Data cannot be read from the card's magnetic stripe	Check that the cards are loaded with the magnetic stripe in the correct orientation. Check whether high or low coercivity cards have been specified. Check that the data conforms to ISO specifications. See Appendix A of this manual for further information.
REJECT BOX FULL	The reject box is full	Empty the reject card box and press the right panel button
MAGNETIC ERROR	The printer cannot detect a magnetic stripe on the card	Check the card orientation
FLASH ERROR		Contact your dealer for technical support
NO ACCESS		



# P420i Plastic Card Printer

## General information

## Getting started

## Operation

## Printing a card

## Cleaning

## Troubleshooting

## Specifications

## Appendix A

## Appendix B

## Appendix C

**Ribbon Errors:** Check that the print ribbon has not 'run out'. Lock and then unlock the print head assembly; this resynchronises the ribbon automatically. When using a color ribbon, it should advance automatically so that the leading edge of the Yellow panel is beneath the print head. Ensure that the correct ribbon type has been specified in the Windows driver.

**Card Feed & Mechanical Errors:** Ensure that the card thickness adjustment has been set-up correctly to allow one card to feed.

**Magnetic Encoding Errors:** Check that the cards are inserted correctly in the printer. Ensure that the cards are low or high coercivity as required, and are set-up correctly in the printer driver.

**Cleaning Alert:** The printer has counted the number of cards printed and has automatically flagged that a cleaning routine needs to be carried out. (See Chapter 4).



# P420i Plastic Card Printer

## 5.2 Print Quality Issues

General information

Getting started

Operation

Printing a card

Cleaning

Troubleshooting

Specifications

Appendix A

Appendix B

Appendix C

This section will help you resolve print quality problems. The print quality is dependent on several factors. The two most important factors that will increase your print quality are cleanliness and card stock. To diagnose and fix print quality problems, follow the troubleshooting procedure below:

- **Small spots appear on the printed card with a non-printed area or a different color.**

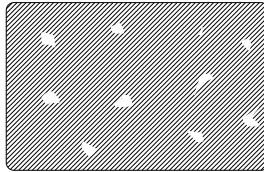

### Possible Cause

- A • Contamination on the card surface.
- B • Dust inside the printer and/or dirty Cleaning Roller.

### >> Solution

- A1 • Check that cards are stored in a dust free environment
- A2 • Use a different supply of cards.

- B1 • Perform a Cleaning of the printer (see Cleaning section).
- B2 • Replace Cleaning Roller (see Cleaning section)

- **There are non-printing horizontal lines (white) on the card surfaces.**

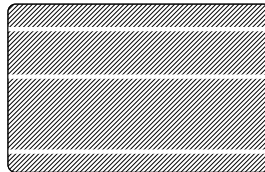

### Possible Cause

- A • Ribbon is not correctly positioned.
- B • Print Head may be dirty.
- C • Print Head elements may have been damaged (e.g. scratched or burnt).

### >> Solution

- A1 • Open cover and press down the Print Head Unlock Lever to open the Print Head carriage. The Print Head will move up.
- A2 • Check that the ribbon is properly rolled onto the ribbon cores and there are no wrinkles in the ribbon.
- A3 • Push down on the Print Head Lock Lever until an audible "click" signals the locked-down position.
- A4 • Ribbon will automatically synchronize.
- A5 • Print again.

- B1 • Perform a Cleaning of the Print Head (see 4.2 Cleaning the Print Head).

- C1 • Call service for Print Head replacement information.



# P420i Plastic Card Printer

General information

Getting started

Operation

Printing a card

Cleaning

Troubleshooting

Specifications

Appendix A

Appendix B

Appendix C

## • Printing shows very pale or inconsistent results.

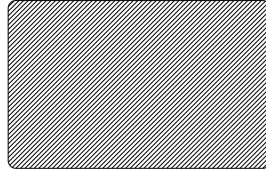

### Possible Cause

- A • Ribbon may have been stored improperly or is damaged.
- B • Cards may not meet specifications.
- C • Contrast and/or Intensity may be set to values which are too high.
- D • Dust or embedded contamination on elements of the Print Head.

### >> Solution

- A1 • Change ribbon and print again.
- B1 • Use a different supply of cards.
- C1 • Adjust Contrast and/or Intensity values in software.
- D1 • Perform a Cleaning of the Print Head (see 4 • 2 Cleaning the Print Head)

## • Printing shows blurry printed image.

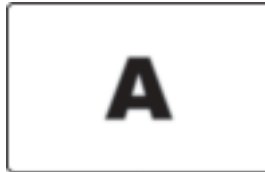

### Possible Cause

- A • Ribbon may not be correctly positioned.
- B • Ribbon may not be synchronized on the correct color panel position.
- C • Cards may not meet specifications.
- D • Dust inside the printer and/or dirty Cleaning Roller.

### >> Solution

- A1 • Open cover and press down the Print Head Unlock Lever to open the Print Head carriage. The Print Head will move up.
- A2 • Check ribbon is properly rolled onto the ribbon cores.
- A3 • Push down on the Print Head Lock Lever until an audible “click” signals the locked-down position.
- A4 • Ribbon will automatically synchronize.
- A5 • Print again.
  
- B1 • Open cover and press down the Print Head Unlock Lever to open the Print Head carriage. The Print Head will move up.
- B2 • Push down on the Print Head Lock Lever until an audible “click” signals the locked-down position.
- B3 • Ribbon will automatically synchronize.
- B4 • Print again.
  
- C1 • Use a different supply of cards.
  
- D1 • Perform a cleaning of the Print Head (See 4 • 2 Cleaning the Print Head).
- D2 • Replace Cleaning Roller (See 4 • 3 Cleaning Cartridge).



# P420i Plastic Card Printer

General information

Getting started

Operation

Printing a card

Cleaning

Troubleshooting

Specifications

Appendix A

Appendix B

Appendix C

• No printing on the card.



**Possible Cause**

- A • Ribbon may not be installed in the printer.
- B • Cards may not meet specifications.
- C • Cable on Print Head may be disconnected.
- D • Print Head elements may be scratched or burnt.

**>> Solution**

- A1 • Check for ribbon in the printer.
- B1 • Use a different supply of cards.
- C1 • Power off the printer and check the Print Head cable connections.
- D1 • Call Service for Print Head replacement information.



For optimum print quality, always keep cover of the printer closed except during ribbon loading and card thickness control procedures.

The card flipper will not operate and an error will be indicated if you try to flip a card with the cover open.





# P420i Plastic Card Printer

General information

Getting started

Operation

Printing a card

Cleaning

Troubleshooting

Specifications

Appendix A

Appendix B

Appendix C

## TECHNICAL SPECIFICATIONS

### General

- High speed printing, over 102 cards/hour edge to edge in full color (YMCKOK) throughput
- Small footprint
- Windows Drivers for 98 and NT 4.0, Win 2000,XP,ME
- One year printer warranty
- One year print head warranty

### Color Printing

- Color dye sublimation or monochrome thermal transfer printing
- 35 seconds per card 2 sides (YMCKOK) throughput
- 300 dpi (11.8 dots/mm) print resolution
- Edge to edge printing standar

### Bar Codes

- Code 39
- Code 128 B & C with & without check digit
- 2 of 5 & 2 of 5 industrial
- UPCA
- EAN8 & EAN13
- PDF 417 2D bar code and other symbologies available via WindCard Classic utility tool (option)

### Fonts

- True Type fonts available via Windows Driver



\*Use only Zebra-approved card and ribbon media. Using non-approved card or ribbon media can void your warranty.

Refer to the accessories section for more information about Card and Ribbon Media available from Zebra Technologies corp.



# P420i Plastic Card Printer

## CARD DIMENSIONS

General information

Getting started

Operation

Printing a card

Cleaning

Troubleshooting

Specifications

Appendix A

Appendix B

Appendix C

### ISO STANDARD DIMENSIONS FOR PLAIN CARD

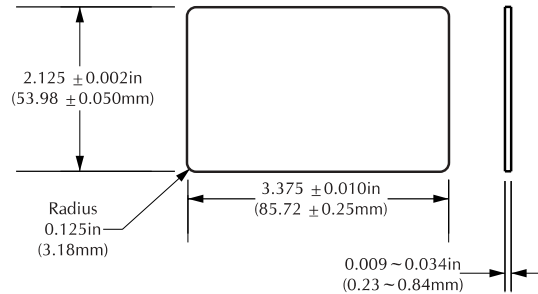

### ISO STANDARD DIMENSIONS FOR MAGNETIC STRIPE CARD

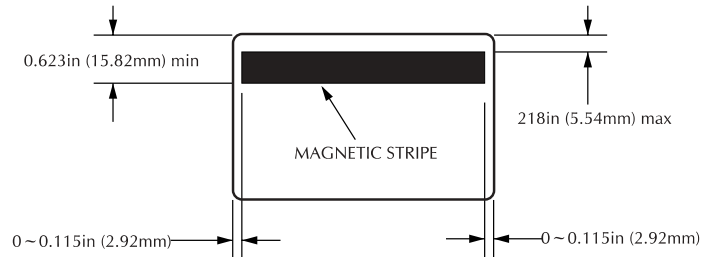

### CHIP POSITION FOR SMART CARD

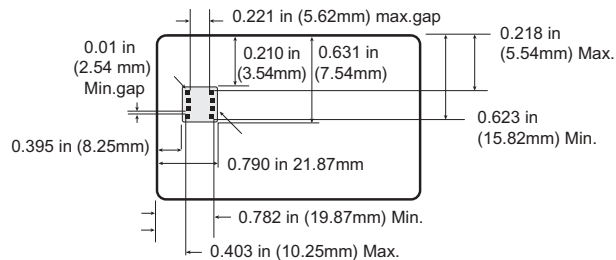



# P420i Plastic Card Printer

## General information

## Getting started

## Operation

## Printing a card

## Cleaning

## Troubleshooting

## Specifications

## Appendix A

## Appendix B

## Appendix C

### Cards\*

- Types PVC, Composite
- Card width/length: ISO CR-80 - ISO 7810, 2.125" (54mm) by 3.375" (86mm)
- Option: Magnetic Stripe - ISO 7811
- Option: Smart Card - ISO 7816-2
- Card thickness: 0.25mm to 1.524m
- Card Feeder capacity: up to 300 cards (10mil), up to 100 cards (30mil)
- Card Output Hopper capacity: 300 cards (10mil), up to 100 cards (30mil)

### Ribbons\*

- Monochrome: 1500 cards/roll
- Monochrome colors: back, red, blue, green, yellow, silver, gold, white.
- K-resin + O: 800 cards/roll
- K-dye + O: 800 cards/roll
- YMCKO: 330 cards/roll
- YMCKOK: 170 cards/roll

### Overlay Varnish

- Thermal transfer
- 4 microns thick
- Clear and holographic options:
  - Clear
  - Genuine/Secure Hologram
  - Custom Hologram

### Interfaces

- Centronics Parallel Standard
- RS-232C Serial (Optional)
- USB port (Optional)

### Mechanical

- Width: 20.9" (523mm†)
- Depth: 10.17" (254.3mm†)
- Height: 10.76" (269mm†)
- Weight: 27.5 lbs (12.5 kg)

### Electrical

- 110 ~ 230 Volts AC, 60 ~ 50 Hz
- FCC Class A, CE, UL, and CUL approved



# P420i Plastic Card Printer

General information

Getting started

Operation

Printing a card

Cleaning

Troubleshooting

Specifications

Appendix A

Appendix B

Appendix C

## Environmental

- Operating Temperature: 60 to 86°F (15 to 30°C)
- Operating Humidity: 20 to 65% non condensing
- Storage Temperature: -23 to 158°F (-5 to 70°C)
- Storage Humidity: 20 to 70% non condensing
- Ventilation: Free air

\* Thermal transfer (Resin) ribbons offer more durability than dye sublimation, with greater resistance to scratches and UV-induced fading.

Dye sublimation printing requires dye sublimation ribbons, with either black or cyan, magenta, and yellow (plus black resin) panels.

† Measured without card output hopper.



General information

Getting started

Operation

Printing a card

Cleaning

Troubleshooting

Specifications

Appendix A

Appendix B

Appendix C

## *APPENDIX A*

---

### *Magnetic Card Stripe Encoder*

This section contains information on the additional operations of the P420i Printers with Magnetic Card Stripe Encoder.  
(See Chapter 2 for location.)

#### **INTRODUCTION**

Operation and maintenance requirements for the P420i Printer with the optional magnetic card stripe encoder.  
(See Chapter 2 for location.)

The magnetic encoder can be set for either high or low coercivity.



# P420i Plastic Card Printer

General information

Getting started

Operation

Printing a card

Cleaning

Troubleshooting

Specifications

Appendix A

Appendix B

Appendix C

## A. MEDIA LOADING ORIENTATION

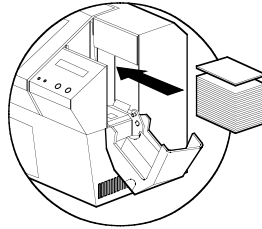

The magnetic encoder is a factory installed item with the read/write head positioned below the card path, available with HICO encoding (P420i CM1 or P420i CEM1) or LOCO encoding (P420i CM2 or P420i CEM2).

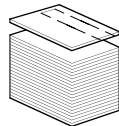

STRIPE  
DOWN

When loading cards into the Card Cartridge, please ensure that the magnetic stripe is facing down and closest to the rear.

Also available are Printer models with the Magnetic Read/Write head positioned above the card path, with HICO encoding (P420i CM3 or P420i CEM3) or LOCO encoding (P420i CM4 or P420i CEM4)

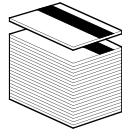

STRIPE  
UP

When loading cards, please ensure that there is a magnetic stripe.

### NOTE:

M1 = Stripe Down HICO  
M2 = Stripe Down LOCO

M3 = Stripe up HICO  
M4 = Stripe up LOCO

Approved HICO & LOCO PVC cards are available. (See Appendix C).



ONLY USE cards that comply with ISO 7810 & 7811 standards for magnetic stripe cards. The magnetic stripe must be flush to the surface of the card to work properly. Never use taped-on magnetic stripes.



# P420i Plastic Card Printer

General information

Getting started

Operation

Printing a card

Cleaning

Troubleshooting

Specifications

Appendix A

Appendix B

Appendix C

## B. MAGNETIC ENCODER CLEANING

There exists two different processes to clean the Magnetic Stripe Encoder. The first process consists of a standard cleaning of the printer. This cleans the most important parts of the printer; including the Print head, Transport Roller and Magnetic Stripe Encoder (refer to chapter 4 "Cleaning" for more instructions).

The second process consists of a cleaning of the Magnetic Encoder using the Menu Button from the LCD Display. To access the Magnetic Encoder Cleaning Menu proceed as below:

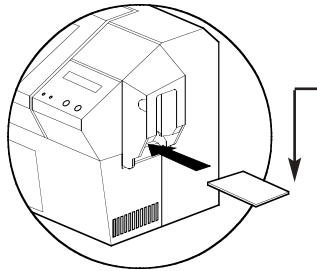

1. Leave power on.
2. Remove cards from the Card Feeder
3. Insert one Pre-Saturated Cleaning Card (provided) through slot on the side of the Card Cartridge.
4. Press the Menu button until the LCD screen shows CLEANING MENU.
5. Press the Select button to select.
6. Press the Menu button again until the LCD screen shows CLEAN MAG HEAD.
7. Run this operation by pressing the Select button.

## ISO STANDARD ENCODING

Track #	Field Separator	Track density	Valid Characters	# of characters
1	^	210 BPI*	Alphanumeric (ASCII 20-95†)	79‡
2	=	75 BPI*	Numeric (ASCII 48-62)	40‡
3	=	210 BPI*	Numeric (ASCII 48-62)	107‡

\* Bit per inch

† Except the '?' character

‡ Including Start, Stop and LCR characters. Also note that these 3 characters are automatically managed by the magnetic encoder according to the ISO Standard Norms.

NOTE: Refer to the Card Printer Programmer's Manual for complete programming information.



# P420i Plastic Card Printer

General information

Getting started

Operation

Printing a card

Cleaning

Troubleshooting

Specifications

Appendix A

Appendix B

Appendix C

## APPENDIX B

---

### Smart Card Contact Station

This section contains information on the additional operations of the P420i Printers with Smart Card Contact Stations. (See Chapter 2 for location.)

#### INTRODUCTION

Smart Cards can have a built-in microcomputer and a battery. Card Memory can store fingerprints, voice recognition patterns, medical records and other such data. The P420i printer may be equipped with an optional contact station for programming Smart Cards (ISO 7816). This printer model responds to commands that position the cards at the contact station, where the printer connects to the contacts on the Smart Cards. All other printer operations remain the same as the standard P420i model.





# P420i Plastic Card Printer

General information

Getting started

Operation

Printing a card

Cleaning

Troubleshooting

Specifications

Appendix A

Appendix B

Appendix C

## A. MEDIA LOADING ORIENTATION

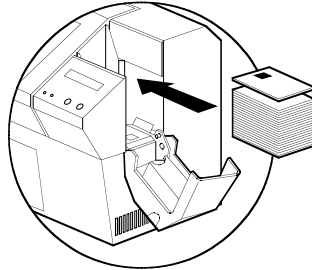

*Position the cards with the Smart Card Chip at the top of the card and towards the printer.*

## B. SMART CARD CONTACT STATION INTERFACE

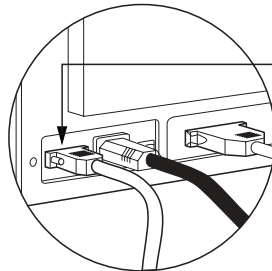

*When a command to the parallel printer interface sends a card to the Smart Card Contact Station, the printer connects the Smart Card Contact Station to the female DB-9 connector on the rear of the printer.*

*An attached external Smart Card Programmer can be used to program Smart card chips.*

DB - 9 PINS	SMART CARD CONTACT POINTS	DB - 9 PINS	SMART CARD CONTACT POINTS
1	C1 (VCC)	6	C6 (Vpp)
2	C2 (Reset)	7	C7 (I/O)
3	C3 (Clock)	8	C8 (RFU)
4	C4 (RFU)	9	(GND when chip is at station)
5	C5 (GND)		

Refer to the Card Printer Programmer's Manual for complete programming information.



**DO NOT** position printing over the Smart Card Chip.



## APPENDIX C

General information

Getting started

Operation

Printing a card

Cleaning

Troubleshooting

Specifications

Appendix A

Appendix B

Appendix C

### Accessories & supplies

Please contact your Zebra-authorized dealer to place an order for accessories and supplies.

#### **RIBBONS**

The following ribbons may be used in the P420i Printer:

Monochrome Resin Ribbons (Sold by the Roll)		
Part Number	Description	
800015-101	Black	1000 images
800015-102	Red	1000 images
800015-103	Green	1000 images
800015-104	Blue	1000 images
800015-106	Gold	1000 images
800015-107	Silver	1000 images
800015-109	White	1000 images
800015-185	Scratch-off Grey	1000 images
800015-301	Black	1500 images

Color Ribbons (Sold by the Roll)		
Part Number	Description	
800015-448	6-Panel Color Ribbon (YMCKOK)	170 images
800015-440	5-Panel Color Ribbon (YMCKO)	200 images
800015-450	2-Panel Black Ribbon (K Dye + O)	500 images
800015-460	2-Panel Resin Ribbon (K Resin + O)	600 images
800015-540	5-Panel Color Ribbon (YMCKO)	250 images
800015-640	5-Panel Color Ribbon (YMCKO)	Value Pack: 20 rolls/pack

**Note:** Y = Yellow, M = Magenta, C = Cyan, K = black, O = Overlay



# P420i Plastic Card Printer

General information

Getting started

Operation

Printing a card

Cleaning

Troubleshooting

Specifications

Appendix A

Appendix B

Appendix C

## CARDS

The following plain white plastic cards are available for use in the P420i printers:

Blank White Cards (Sold by the box)	
Part Number	Description
<b>Premier Grade PVC</b>	
104523-114	Card, 10 mil † ‡ (5 packs of 200)
104523-010	Card, 10 mil ‡ adhesive back (5 packs of 200)
104523-111	Card, 30 mil † (5 packs of 100)
104523-112	Card, 30 mil -low coercivity Mag. Stripe (5 packs of 100)
104523-113	Card, 30 mil -High coercivity Mag. Stripe (5 packs of 100)
<b>Premier Plus Grade (PVC composite 60/40)</b>	
104524-101	Card, 30 mil (5 packs of 100)
104524-102	Card, 30 mil -low coercivity Mag. Stripe (5 packs of 100)
104524-103	Card, 30 mil -High coercivity Mag. Stripe (5 packs of 100)

### Notes:

† 10mil = 0.254mm; 30 mil = 0.762mm

‡ 10mil cards are recommended for single side printing monochrome only.

*Many other card types are also available; ask your dealer for more information.*



# P420i Plastic Card Printer

[General information](#)

[Getting started](#)

[Operation](#)

[Printing a card](#)

[Cleaning](#)

[Troubleshooting](#)

[Specifications](#)

[Appendix A](#)

[Appendix B](#)

[Appendix C](#)

## ACCESSORIES

Accessories available for P420i Printers appear below. Always refer to the part number when placing an order.

Printer Supplies	
Part Number	Description
300320-001	Centronics Parallel Cable (36 pins)
105909-112	Replacement Print Head Kit

Cleaning Supplies	
Part Number	Description
105909-169	Premier Cleaning Kit (25 swabs, 50 cards)
105912-003	Adhesive Cleaning Roller Kit (set of 5)
105912-002	Cleaning Cartridge, complete
105909-055	Cleaning Card Kit (box of 100 cards)
105909-057	Cleaning Swab Kit (box of 25 swabs)

Miscellaneous	
Part Number	Description
806503-001	Card Punch (slots card for lapel clip)
104527-001	Lapel Clips (pack of 100 clips)



**Card  
Printer  
Solutions**

# P420i Plastic Card Printer

## *World Wide Sales and Support:*

### General information

**Zebra Technologies Corporation  
Card Imaging Division**  
1001 Flynn Road  
Camarillo, CA. 93012-8706.USA  
Phone:+1 (805) 579 1800  
Fax.:+1 (805) 579 1808  
Toll Free in US: (800) 452-4056  
e-mail: cards@zebracard.com

### Getting started

### Operation

### Printing a card

### Cleaning

### Troubleshooting

**Zebra Technologies Corporation  
Card Imaging Division, (Europe, Middle East, Africa)**  
The Valley Centre, Gordon Road, High Wycombe  
Buckinghamshire HP13 6EQ, England  
Phone: +44 (0) 870 241 1527  
Fax.: +44 (0) 870 241 0765  
e-mail: eurosales@zebracard.com

### Specifications

### Appendix A

**Zebra Technologies Corporation  
Card Imaging Division, Latin America**  
6175 NW 153rd Street, Suite # 121  
Miami Lakes, FL 33014 USA  
Phone: +1 (305) 558 8470  
Fax: +1 (305) 558-8485  
e-mail: latinsales@zebracard.com

### Appendix B

**Zebra Technologies Corporation  
Card Imaging Division, Asia/Pacific**  
1 Sims Lane #06-11  
387355 Singapore  
Phone:+65 84 20 322  
Fax.:+65 84 20 514  
e-mail: asiasales@zebracard.com

### Appendix C

**CORPORATE HEADQUARTERS**  
Zebra Technologies Corporation  
333 Corporate Woods Parkway  
Vernon Hills, IL 60061-3109 USA  
Phone: +1 (847) 634 6700  
FAX: +1 (847) 913 8766  
e-mail: sales@Zebra.com

Website: [www.zebracard.com](http://www.zebracard.com)



**Zebra Technologies Corporation**